

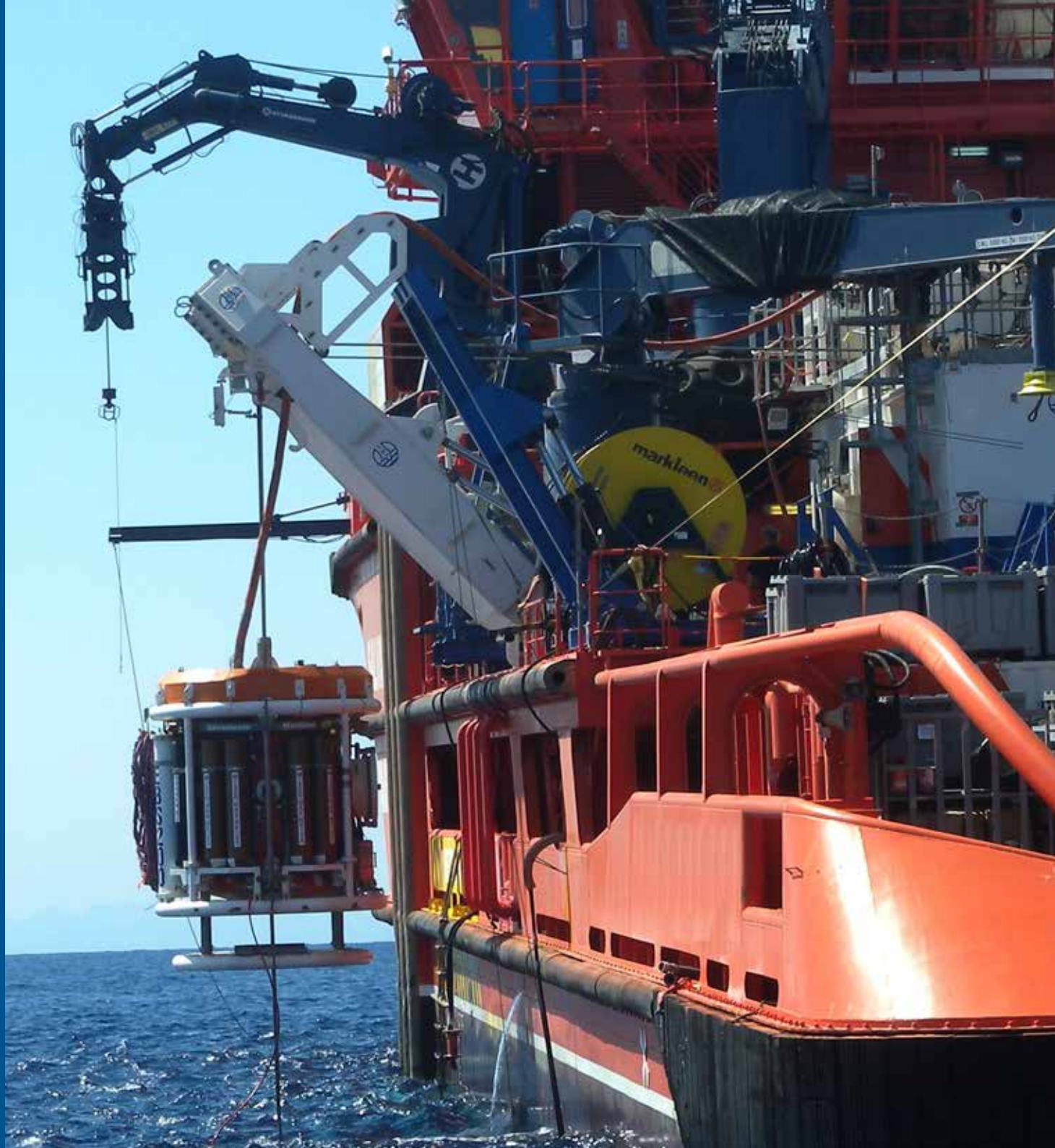

SATURATION DIVING

www.smp-ltd.com



WHAT WE DO



SMP has established itself as a leader in the field of underwater technology, meeting the specialised needs of the saturation diving industry. With a strong focus on innovation, we provide state-of-the-art solutions for commercial diving, subsea technology, and hyperbaric systems. Our consistent track record of delivering high-quality products and services has allowed us to extend our reach to dive contractors and marine organizations across the globe, setting new industry benchmarks for performance, reliability, and safety.

As we continue to expand our international footprint, SMP operates on a global scale, offering a comprehensive range of products, services, and ongoing support tailored to the complex requirements of the saturation diving industry. From commercial dive operations to offshore projects, SMP is committed to providing the equipment and technology necessary to ensure the success and safety of deep-sea missions. Our unwavering dedication to excellence has made SMP a trusted partner for dive contractors worldwide.

OUR VALUES



D Driven - At SMP we have the drive not only to make high quality systems but also to make the industry safer for the personnel who operate in it. The drive to innovate has made us a globally recognised name for state of the art solutions.

E Efficient - Our experience and knowledge allows us to design and manufacture state of the art solutions much more efficiently and effectively. We are able to transfer the knowledge from a multitude of previous projects to use in new projects to quickly and effectively create solutions to our clients' requirements.

P Professional - With a long established history and a range of past projects, SMP are able to provide professional advice and solutions based on many years of knowledge and experience. SMP are members of various organisations including IMCA, ADC, and SMERWG.

T Thorough - We pride ourselves on our attention to detail. SMP want to create a system that meets the clients unique requirements whilst also solving all of the problems they face.

H Hard Working - SMP endeavour to create only the best solutions for our clients. We work closely with the client to understand all of the problems they face and what they want to achieve from a system. Our team can travel to meet clients face to face at their premises.

OUR MARKETS



**Military /
Defence**

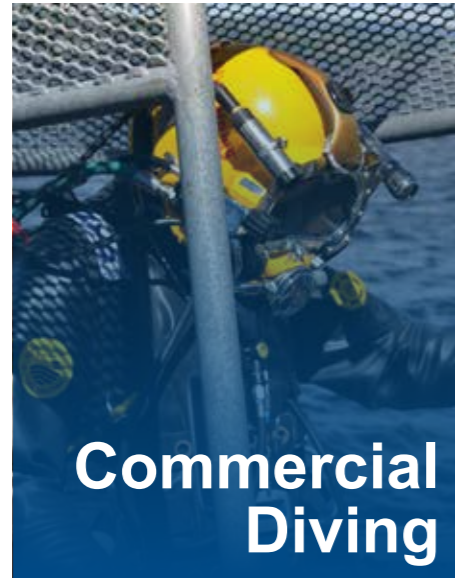

**Commercial
Diving**

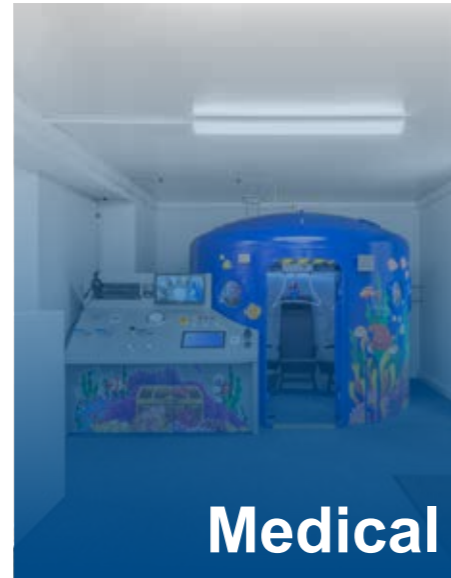

Medical

SMP have a long established history in the Commercial Diving industry. Since our founding in 1985, we have expanded into adjacent markets and industries. We now operate in many global market sectors including Military, Marine, Renewables. Nuclear, Tunnelling and Medical Industries, with clients across the world.

We are always increasing the set of markets we serve as we bolster the solutions we manufacture. We thrive on innovating our systems to work in even more unique ways to tailor them to the bespoke needs of each sector.

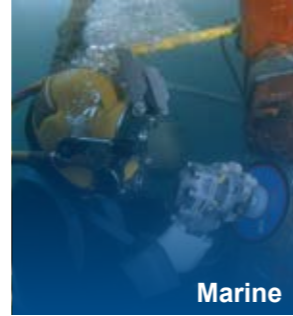

Marine

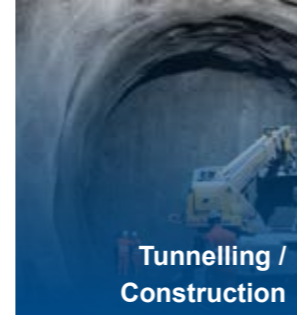

**Tunnelling /
Construction**

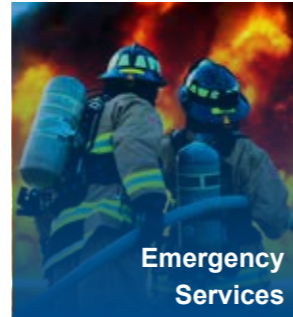

**Emergency
Services**



**Hyperbaric Oxygen
Therapy (HBOT)**



Nuclear



Offshore Energy

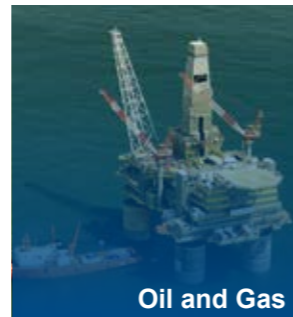

Oil and Gas

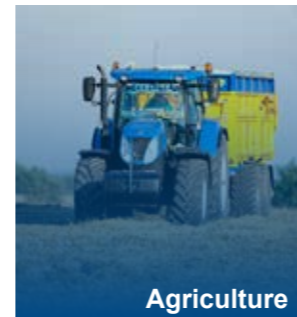

Agriculture

PROJECTS ARE MADE BY PEOPLE AND EXPERTISE



People are the primary asset of every business and SMP is no different. We are proud to be a strong and diverse team dedicated to delivering the very best to our clients. SMP focuses on continual development, investing in the latest training, support, tools and techniques to achieve outstanding results on a consistent basis.

Over our long history we have been involved in a range of different projects. These projects have been in a variety of industries and have spanned across the globe.





SMP provides cutting-edge solutions for saturation diving, offering a comprehensive range of systems designed for various applications. With a global presence, we specialize in the design, manufacture, and delivery of state-of-the-art saturation diving systems to clients worldwide.

Our engineering team brings decades of experience to the table, having worked extensively with Saturation Diving Systems across a wide range of industries. We have successfully designed, built, and installed advanced diving setups for shipbuilders, vessel owners, and offshore diving contractors across the globe.

At SMP, we believe in a client-centered approach. We take the time to fully understand your unique requirements and operational goals before developing a solution that is both innovative and practical. Our expertise allows us to deliver projects on schedule and within budget, ensuring you receive the highest quality systems without compromise.

Each system we produce is custom-built to meet the specific needs and preferences of our clients, including the option for systems rated up to 300 MSW (Meters of Seawater). Whether you need a compact solution for a specific vessel or a large-scale system for an offshore platform, SMP has the capability to design and construct to your exact specifications. Our team of engineers is always available to offer expert advice, guiding you in choosing the most appropriate specifications and configurations for your operational environment.

SATURATION DIVING

SATURATION DIVING

1. Diving Bell
2. Launch and Recovery Systems (LARS)
3. Self-propelled Hyperbaric Lifeboats (SPHL)
4. Machinery Containers
5. Decompression Chambers
6. Chamber Control Room
7. Air/Gas Storage
8. High Pressure/Low Pressure Compressors
9. Hot Water Machine
10. Gas Generation Systems
11. Diving Personnel Equipment

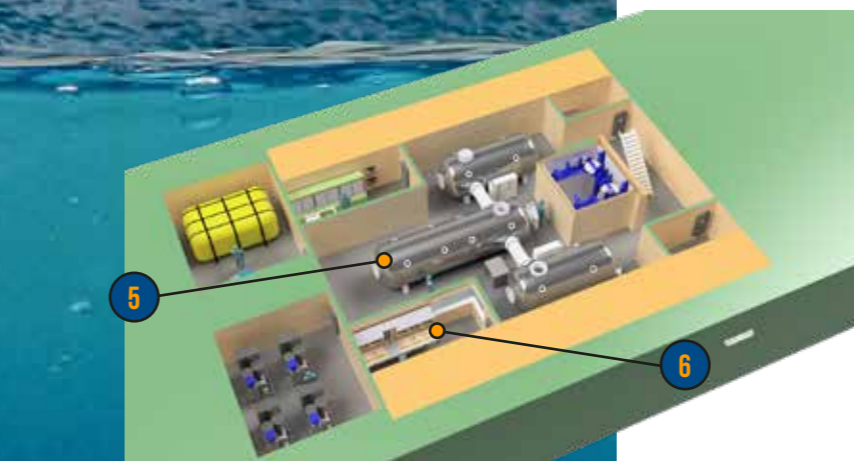
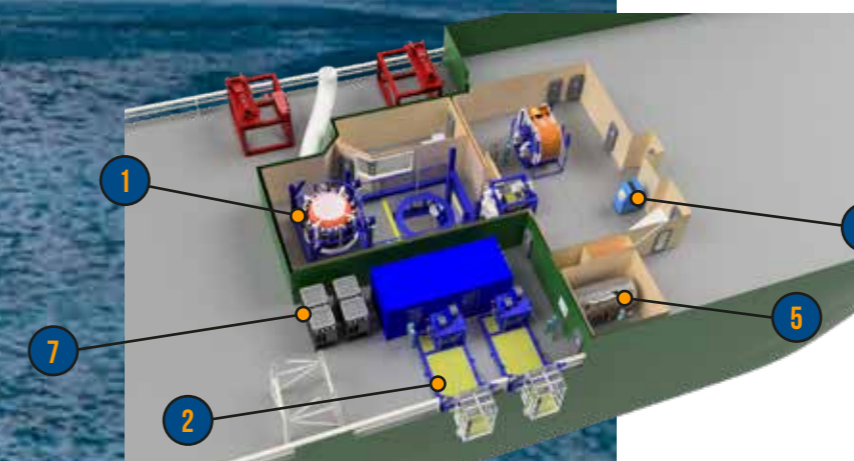
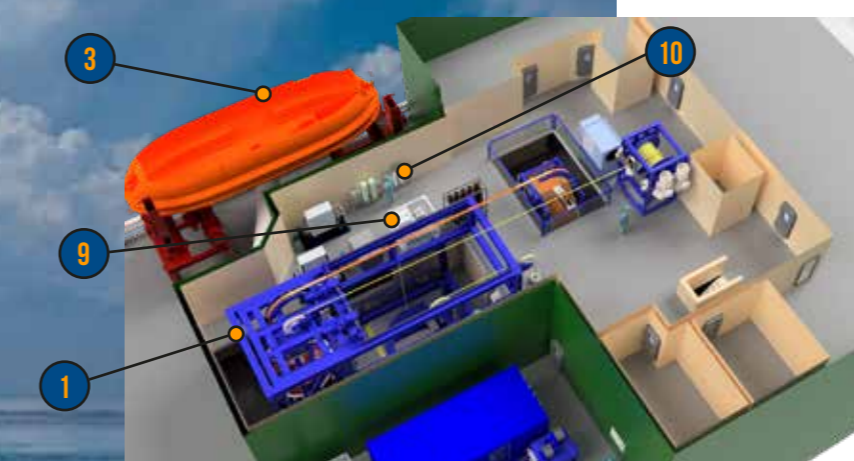



OUR RANGE OF SATURATION SYSTEM VARIANTS

ON-DECK MODULAR

These systems are designed for customers and markets who want a high end operational capability but with the flexibility to move the system between vessels and rigs for different campaigns and projects, these systems don't typically have a SPHL but they can have a HRC or HRB depending on regulatory requirements, similarly these systems are usually certified and supplied in accordance with IMCA requirements. Available in a range of depths from 50m to 300m SMP can provide a range of systems for inshore or offshore work.

INBUILT MODULAR

These systems are designed/typically used for vessel conversion projects where customers want the increased weather protection and operational benefits of a fully inbuilt, below deck integrated system provides but packaged in a modular way, typically we use a repurposed system to system like this where customers are looking to get long term capability into the market quickly. Modular in design these systems are efficient and easy to integrate.

FULLY INTEGRATED

These systems are usually new build systems designed and built as part of a new build vessel project, weight or space optimized these systems are usually classed. Twin bell or single these systems offer the best long term solutions for customers who are committed to providing a long term saturation diving capability.

Equipment can be provided on a new build basis or alternatively depending on time line can be built using existing repurposed tankage. We can build systems to meet the requirements of all the bigger IACS classed societies like Lloyds, ABS or DNV.



ON-DECK MODULAR SOLUTION

SMP specialises in constructing saturation diving systems, which are designed to support deep-sea diving operations. One of these system type variants is the on-deck modular system that can be installed on the decks of vessels or barges. These systems are often used to facilitate complex underwater tasks, such as maintenance, repair and construction. This variant of solution differs as it involves integrating all components into a cohesive, large-scale modular system. This modular approach allows for flexibility in deployment, enabling easy customisation, expansion, or relocation of the equipment to meet the specific needs of various projects or environments. Each unit works seamlessly together to ensure efficient, safe, and reliable diving operations.



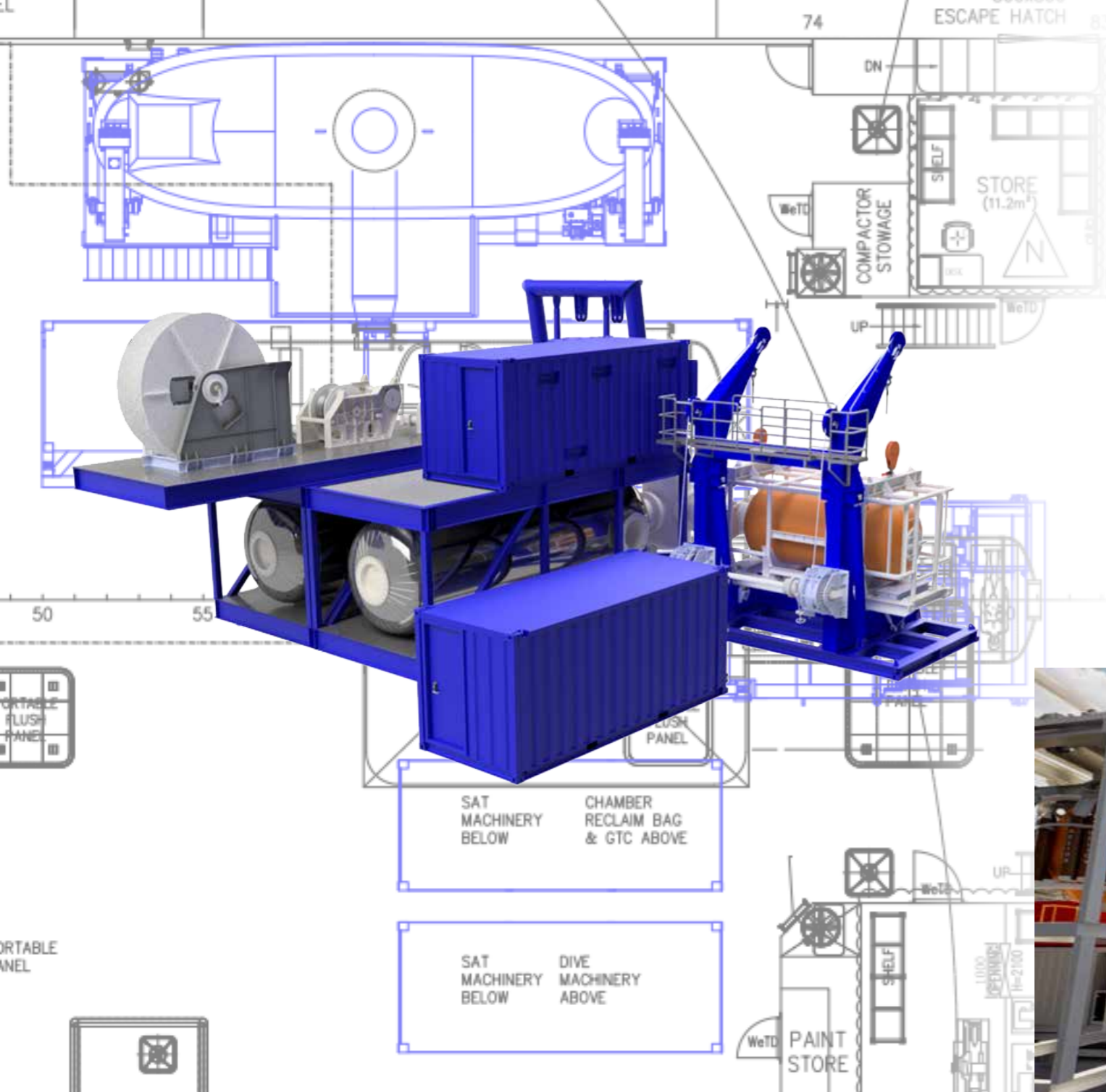

ON-DECK MODULAR SOLUTION

On-deck or barge-mounted saturation diving systems offer a number of advantages over other types of saturation diving systems. These benefits are:

One of the most significant advantages of on-deck or barge saturation diving systems is their ability to be deployed on a variety of vessels or barges. Unlike land-based or platform-fixed systems, on-deck systems can move from one location to another, offering flexibility in deployment.

These systems can be more cost effective than their platform or land-based counterparts. This is because they are built for this specific use of saturation diving. They can be deployed to the location of the operation instead of having to construct infrastructure. It is this mobility that reduces the downtime on projects as the system is moved to where it is needed.



COMPONENTS OF ON-DECK SOLUTIONS

On Deck saturation diving solutions include various components to make a complete system. These components include:

Saturation Diving System: This includes an A-frame and the diving bell which moves divers between the working area to the on-deck living chambers and supporting machinery.

Living Chambers: We design pressurised / decompression chambers that the saturation divers live within during the period of their diving contract. These chambers can be made to the size/ occupancy requirements of the client, making sure it fulfils the requirements whilst utilising the limited space.

Dive/Chamber Control Rooms: These are designed to hold the communications devices, video monitoring systems, air control panels for the chambers and the divers, and other equipment to monitor diver vitals and activity. These are typically built within 10ft or 20ft ISO containers, making them compact and easier to move should the need arise.

Gas Generation, Storage and Management Systems: SMP work with key gas handling manufacturers in the industry to supply low pressure and high pressure compressors that can supply various gasses including oxygen, heliox and nitrox. We also manufacture gas cylinder quads for storage of gasses, and can be configured to meet the capacities required.

Launch and Recovery Systems: SMP design and manufacture various LARS including single and twin baskets, as well as wet bells. These systems are designed to fit within a standard 20 foot ISO container so that it can be safely stored when it is not required whilst also optimising limited deck space.





INBUILT MODULAR SOLUTION

Converting, upgrading, or repurposing existing vessels to take on new roles can often be a more cost-effective and time-efficient solution compared to designing and building an entirely new asset. However, major vessel conversions and refits come with a unique set of challenges. These complex projects demand thorough evaluation, planning, and precise execution to ensure success.

At SMP, we specialise in simplifying this process with our efficient system design methodology. Our team guides you through every stage of converting and repurposing a vessel, ensuring that all aspects are handled with expertise and attention to detail. Leveraging our extensive network of industry contacts and partner organisations, we deliver tailored solutions, including state-of-the-art saturation diving systems for vessels undergoing conversion. By choosing SMP, you gain access to the resources and expertise necessary to transform your vessel into a high-performance asset, fully equipped for its new role.

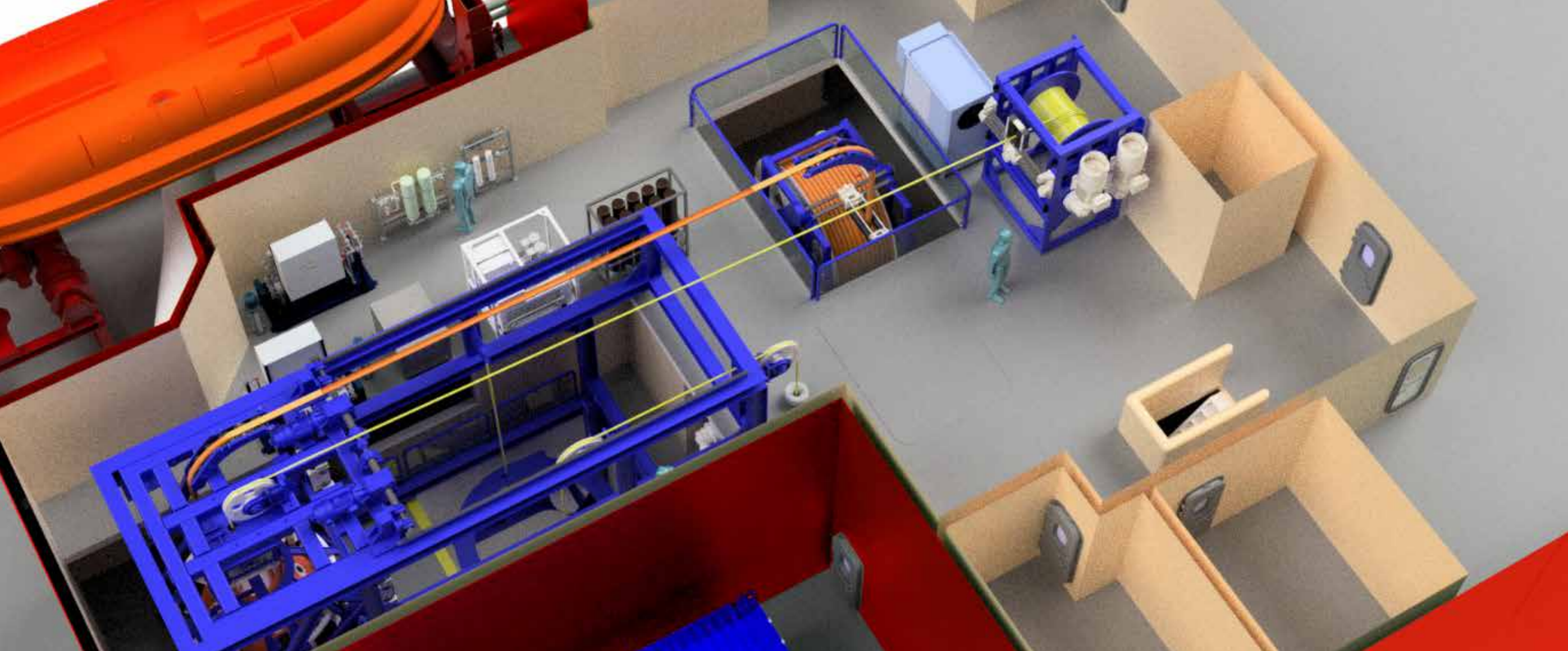



BENEFITS OF VESSEL CONVERSIONS

Converting an existing vessel is more cost-effective than constructing a new one, especially for the highly specialised role of saturation diving. The expense of designing and building a new ship from the ground up can be significant, while converting an existing vessel allows operators to take advantage of its current structure and systems, reducing overall costs. This approach also eliminates the need for additional capital investments in new shipyards or facilities.

In addition to cost savings, vessel conversions offer a faster turnaround compared to new builds. Constructing a new vessel can take several years, from design through to delivery, whereas a conversion project can be completed in a much shorter timeframe. This allows operators to meet operational demands more quickly, ensuring that the vessel is ready for service without lengthy delays. The ability to respond swiftly to industry needs is a key advantage in competitive markets such as offshore diving and marine construction.



COMPONENTS OF VESSEL CONVERSIONS

The heart of the conversion involves installing a saturation diving system, which includes a pressurised living habitat (the dive chamber), where divers live while working at depth, as well as a transfer capsule (or diving bell) that moves divers between the chamber and the worksite underwater.

For saturation diving, a vessel needs to remain stationary over a specific underwater location for extended periods. Dynamic Positioning systems, which use thrusters and sensors to maintain the vessel's position without anchoring, are essential for ensuring the safety of divers and the precision of underwater operations. Installing or upgrading DP systems is often part of the conversion process.

Saturation diving requires specialised deck handling equipment such as cranes, winches, and umbilical management systems. These are used to deploy the diving bell, manage cables, and handle heavy equipment needed for underwater tasks. The vessel's deck space may need to be reconfigured to accommodate this equipment.

A vessel undergoing conversion for saturation diving must be fitted with sophisticated life support systems that manage air pressure, oxygen levels, and temperature within the habitat. Additionally, hyperbaric medical facilities are often required on board to treat potential health issues such as decompression sickness.

Since saturation diving operations can last weeks, vessels must be equipped with suitable accommodations for divers and crew. This includes sleeping quarters, kitchens, recreational areas, and workspaces, all of which need to meet the requirements of extended offshore operations.



MAIN DECK

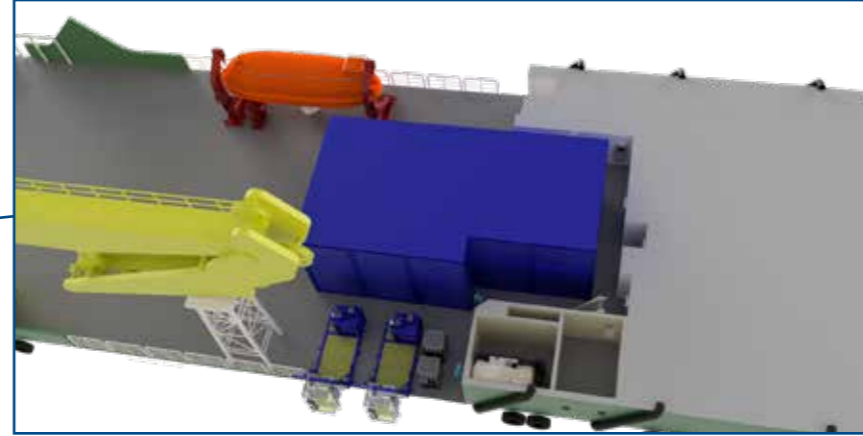
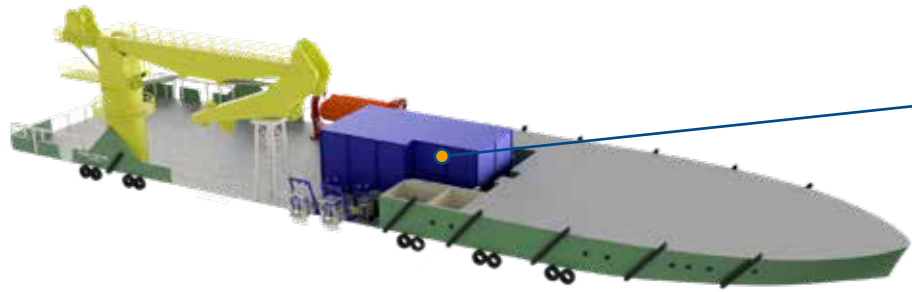

TWEEN DECK

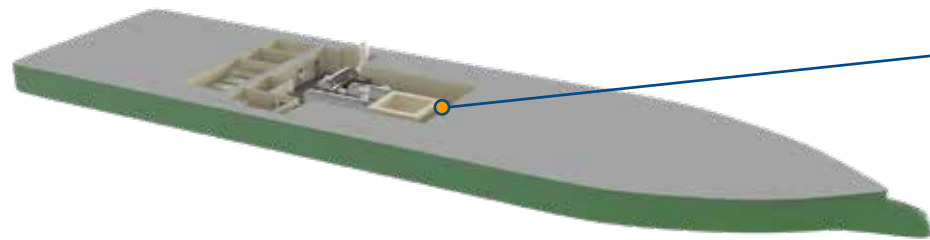

TANK TOP

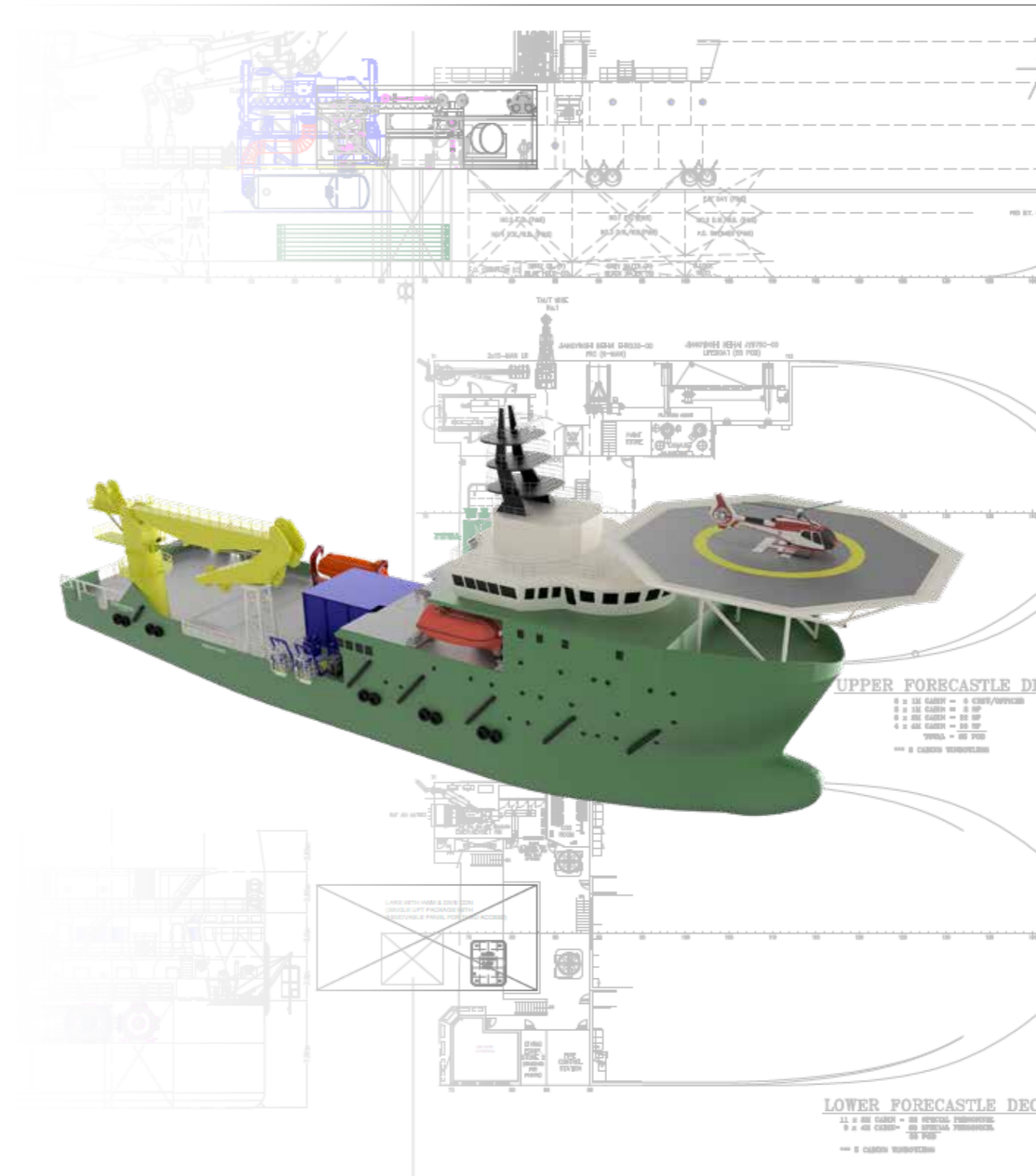
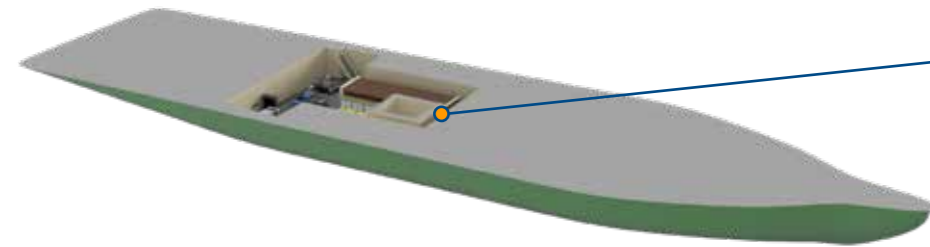

FULLY INTEGRATED SOLUTION

SMP recently designed an inbuilt modular saturation diving solution which included a 12-person Saturation Diving System, designed for a working depth of 300 meters. The specification of the system was developed in line with the client's requirements. To reduce both costs and lead times, key components of the system were refurbished equipment, which were restored to high standards and re-certified as needed.

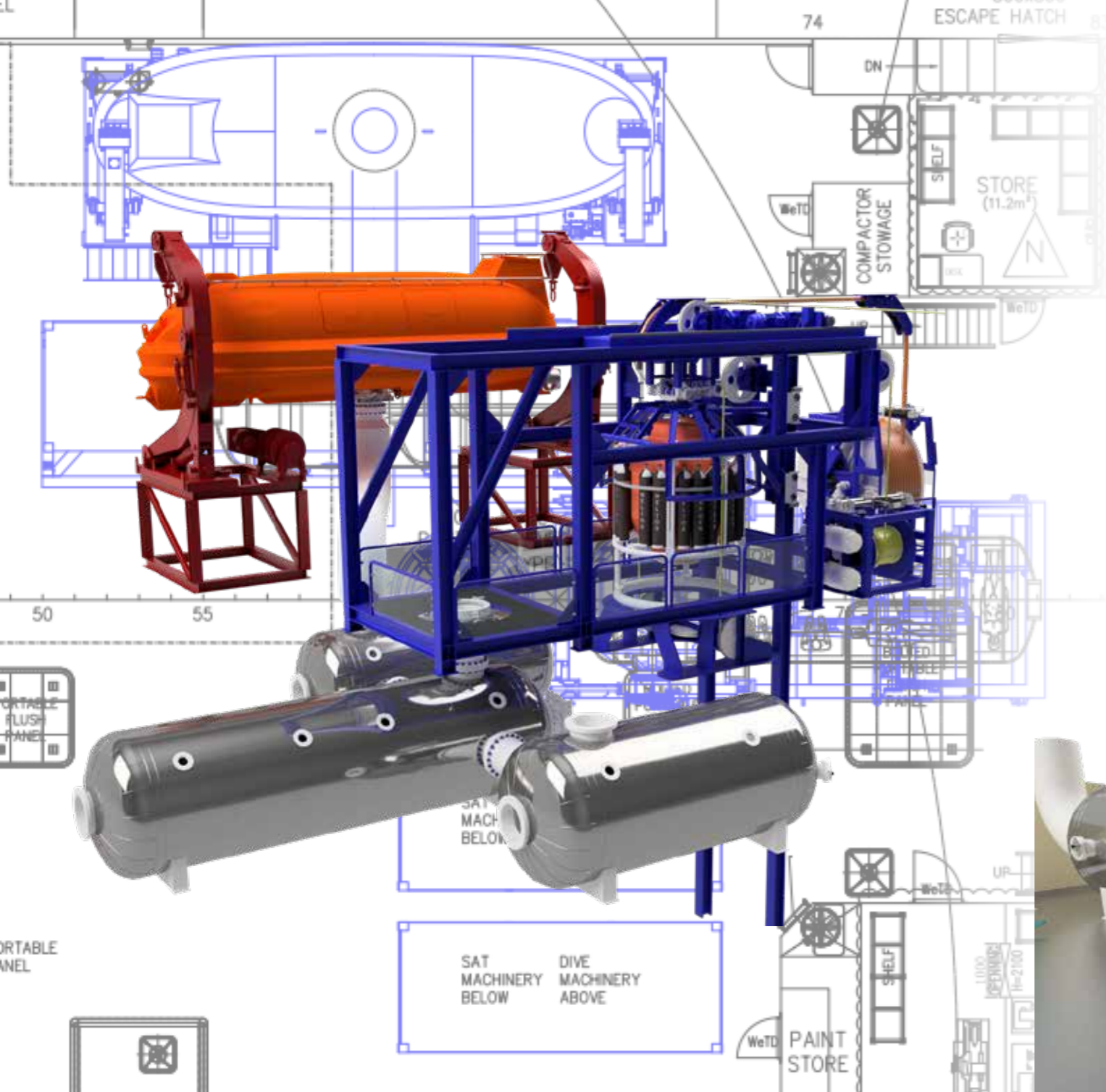

SUPPORTING UP TO 12 DIVERS

The saturation diving complex and its associated equipment supports up to 12 divers, arranged into four dive teams, operating at depths of up to 300 meters seawater (msw). All divers are housed in the main lock of a twin-lock Deck Decompression Chamber (DDC). The entry lock of each DDC facilitates Transfer Under Pressure (TUP) between the DDC locks and the diving bell. In case of emergency, a Self-Propelled Hyperbaric Lifeboat (SPHL) will be available, accommodating all 12 divers for evacuation and rescue. Due to the layout of the chambers and the location of the SPHL transfer trunk, the SPHL will not provide support for split-depth saturation operations.

MODULAR FOR EASE OF INSTALLATION

The diving bell will accommodate two working divers and one standby diver. With the chambers located on the enclosed tween deck and the Launch and Recovery System (LARS) with the bell positioned on the main deck, diver transfer between the bell and DDC1 TUP will be achieved via a bell bottom mating manway and a deck-penetrating transfer trunk. The bell will be deployed using a hydraulic-powered winch with galvanised steel wire. A clump weight system, also deployed by a hydraulic winch, will provide emergency recovery and anti-twist functionality. A hydraulically powered umbilical winch will manage the storage and deployment of the main umbilical as the bell descends and ascends. All hydraulic services will be powered by a dedicated Hydraulic Power Unit (HPU).

To minimise vessel modifications and reduce installation time, the system will be modularised as much as possible, with pre-packaged skid units. Service interface plates and junction boxes will be clearly marked to simplify system integration. This modular design will ensure efficient installation and operation while optimising the available space on the Dive Support Vessel (DSV). The result will be a streamlined, efficient system with a reduced footprint.

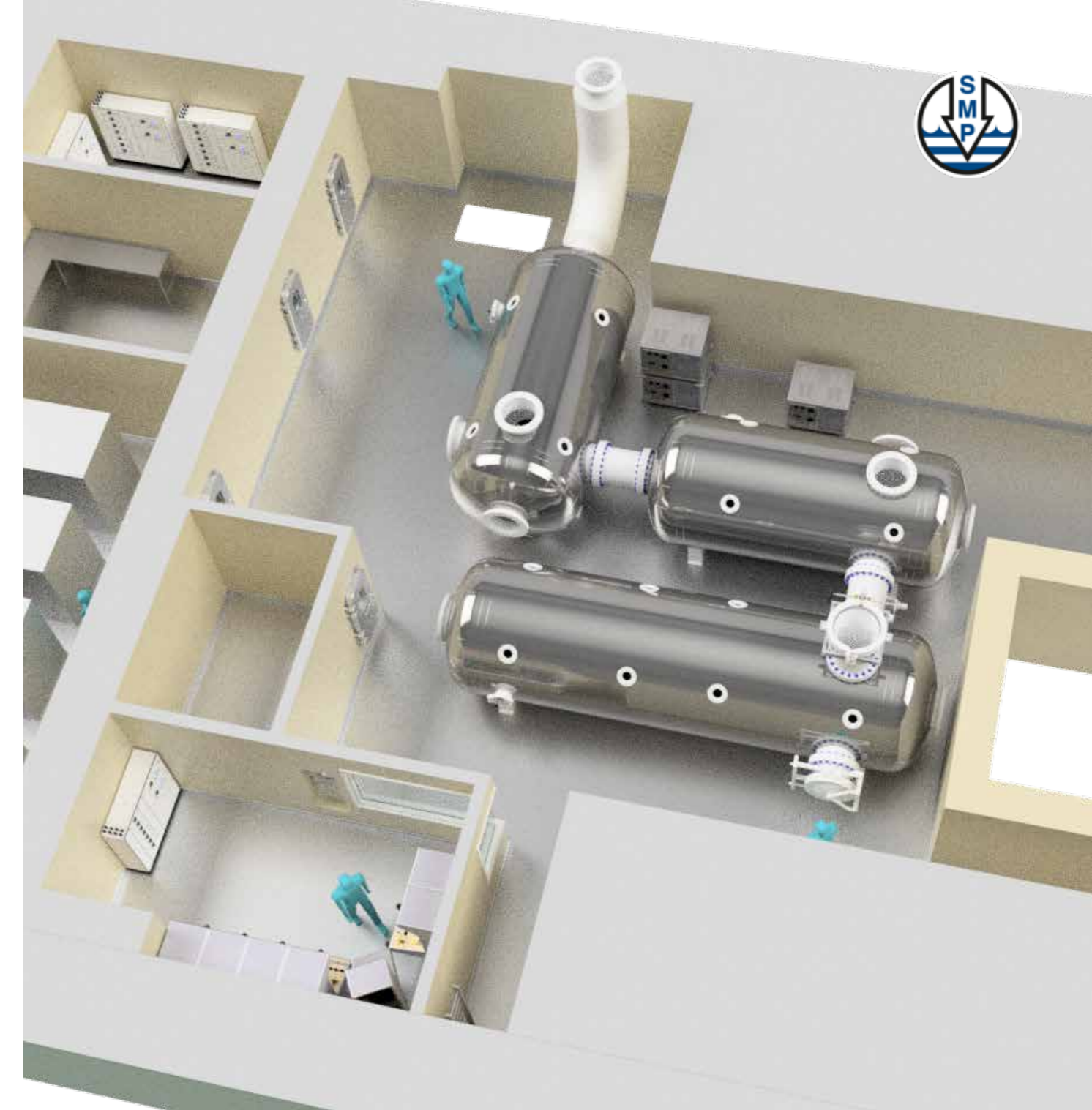



TRAINING LARS SOLUTION

SMP is a global leader in the design and manufacture of advanced saturation diving training facilities. With a commitment to innovation and excellence, we provide highly specialised and customised solutions that cater to the unique needs of professional diving institutions around the world. Our expertise spans from conceptual design to full-scale production, ensuring that each facility is tailored to meet the specific requirements of our clients, whether for commercial, military, or academic purposes.

We understand the complexity of saturation diving and the critical importance of safety, reliability, and efficiency in training environments. Our state-of-the-art systems are designed to replicate real-world conditions, providing divers with immersive and practical experience in deep-sea operations. Each facility is engineered with cutting-edge technology, adhering to the highest industry standards and regulations.



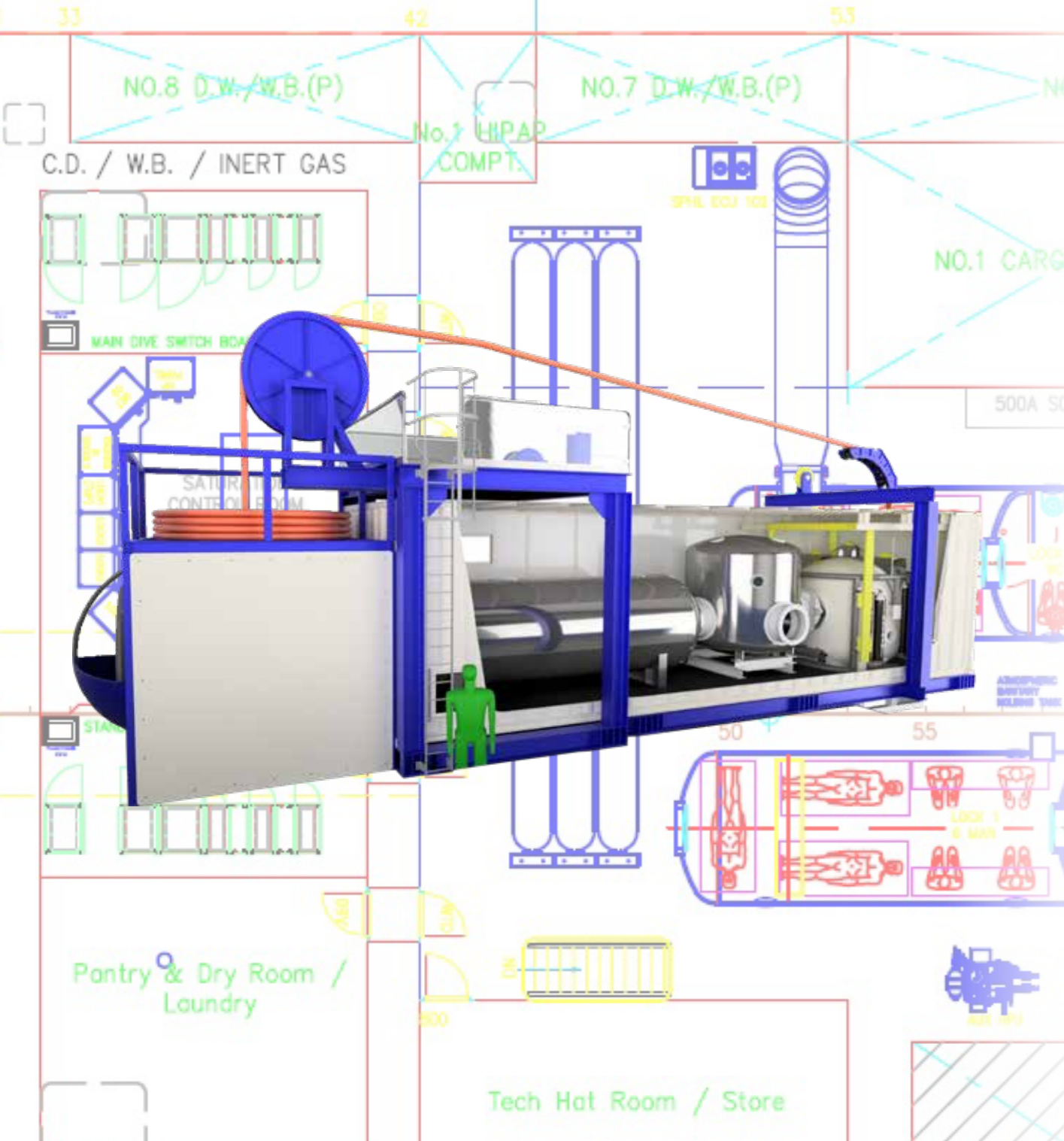

TRAINING THE NEXT DIVERS

Our Closed Bell Training Facility offers an all-encompassing training platform designed specifically for saturation diving. This advanced facility provides divers with the opportunity to gain in-depth knowledge and hands-on experience required for safe and efficient operations in the demanding conditions of deep-sea environments.

The training system simulates real-world underwater scenarios, including the use of a closed bell, which is essential for safe diver transfer under pressure in deep-sea diving. By immersing divers in these controlled yet highly realistic environments, the facility helps trainees develop critical skills such as managing complex equipment, working in confined spaces, and operating under extended pressure conditions.



EXCEEDING THE STANDARDS

The SAT Diving Training System offers a comprehensive solution for saturation diving instruction, providing trainees with realistic, hands-on experience in controlled environments. By simulating real-world deep-sea diving conditions, the system allows divers to develop the skills and confidence necessary for complex underwater operations.

Designed with portability in mind, the facility is highly versatile, allowing it to be easily transported and installed at various locations as required. This flexibility makes it ideal for institutions that need to set up temporary or mobile training stations without compromising the quality of the training.

One of the key features of this system is its ability to be installed on pre-existing infrastructure, such as barges. In our current project with the Professional Divers Academy, the facility is being successfully integrated into a pre-existing barge, demonstrating its adaptability and ease of deployment.

The facility is fully IMCA compliant, adhering to all the safety and operational standards established by the International Marine Contractors Association. This ensures that the training system meets the highest industry benchmarks, providing a safe and reliable environment for trainees.

To meet the required delivery timeline, the facility has undergone partial refurbishment. While some components have been updated or modified, the integrity and quality of the system remain uncompromised, ensuring that it meets both the performance expectations and the deadline.

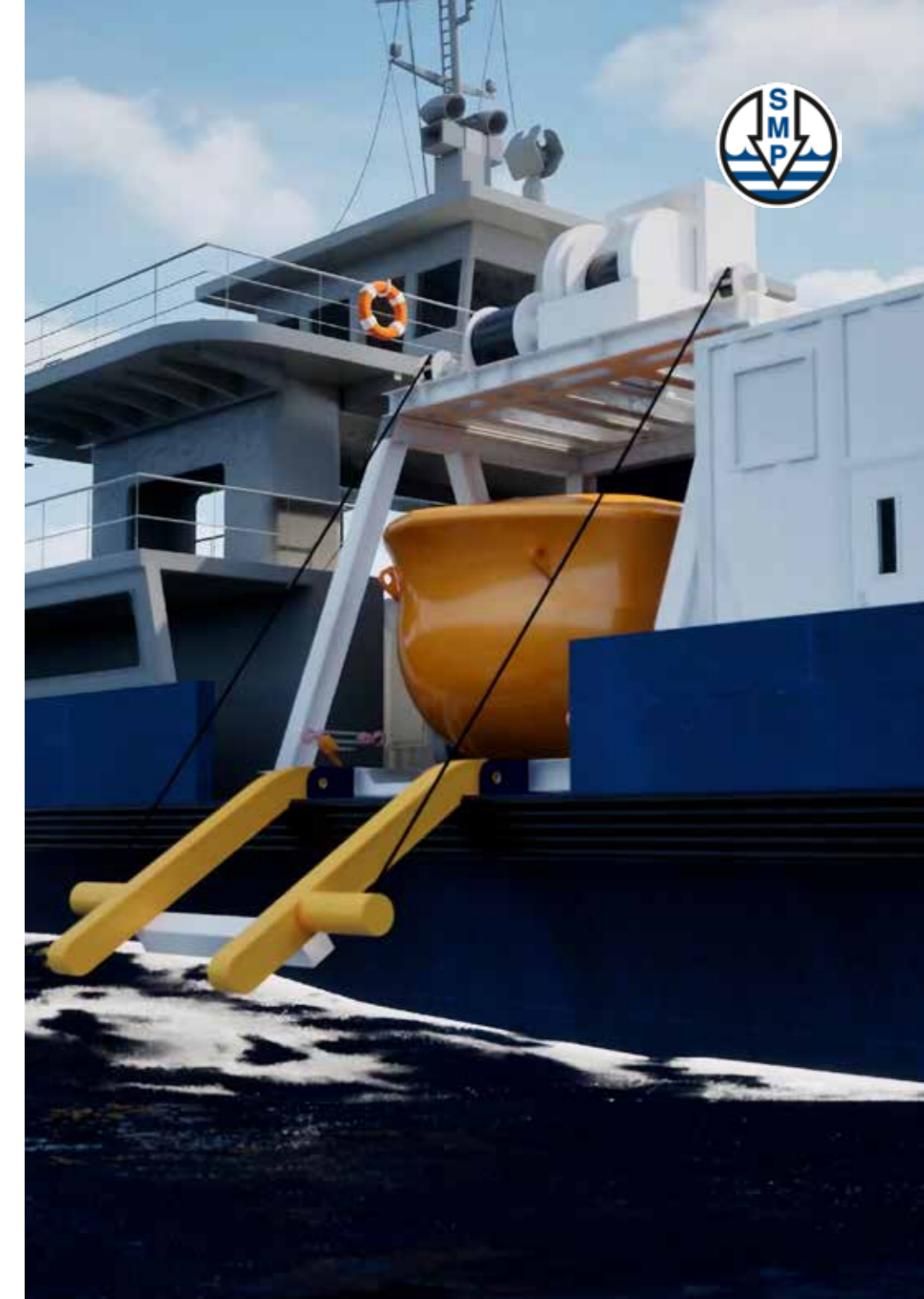

TRANSFER UNDER PRESSURE (TUP)

The TUP Diving System is a Closed Bell Diving System, developed and manufactured by SMP, and certified according to International Maritime Contractors Association (IMCA) guidelines and best practices for offshore diving operations. It is also certified by Lloyds Register of Shipping.

This system supports both air and mixed gas diving, and its clump weight includes a tool basket for divers. An optional hyperbaric floataway chamber can be added. The compact, modular system features a 3-man, 4.7m³ saturation diving bell, diver gas control panels (air/mixed gas), main bell/diver control panel, twin-lock decompression chamber, and an optional single-lock decompression chamber. It is also equipped with HP and LP compressors, and a gantry launch and recovery system.

The system is mobile and modular, suitable for deployment on support vessels, platforms, rigs, or construction barges, and is designed for either moon pool or over-the-side operations. By using Trimix or Nitrox gas mixtures, divers can achieve longer bottom times at greater depths compared to standard air diving, which requires extended decompression periods. The closed bell system enhances safety by transferring divers in a protected environment, eliminating the risk of nitrogen intoxication. This is ensured by preventing any exposure to atmospheric pressure during decompression.



SPHL

Our advanced system features a traditional Deck Decompression Chamber (DDC) securely enclosed within a buoyant lifeboat hull, providing a safe and stable environment for divers during decompression, even in harsh offshore conditions. Equipped with onboard gas supplies and high-capacity batteries, this system ensures over 72 hours of continuous life support, offering divers extended protection and safety during critical operations.

Designed for full autonomy, this lifeboat system is self-propelled, allowing for independent operation without the need for a tow vessel. This feature provides greater flexibility and rapid response capabilities in emergency situations. For added convenience and safety, the system typically includes a bottom-entry manway, allowing for easy and secure access to the chamber in a variety of conditions.



HRC

Our Deck Decompression Chamber (DDC) is equipped with a robust bump frame and advanced buoyancy aids to ensure stability and safety during operations. Designed with durability and reliability in mind, this system provides a secure environment for divers undergoing decompression, even in challenging offshore conditions. Each DDC is outfitted with onboard gas supplies and high-capacity batteries, delivering over 72 hours of continuous life support for divers. This extended autonomy enhances safety, ensuring that divers are protected even in prolonged or unexpected situations.

Our Hyperbaric Rescue Chambers (HRCs) are designed to be towed by a supporting vessel, significantly reducing production and operational costs. This towable feature not only minimises the need for complex onboard systems but also offers flexibility in deployment, making it a highly efficient and economical solution for hyperbaric rescue scenarios.

HRB

Introducing SMP's exclusive design that combines the safety of a Self-Propelled Hyperbaric Lifeboat (SPHL) with the functionality of a Hyperbaric Rescue Chamber (HRC). This innovative solution offers unparalleled protection and efficiency for divers in emergency situations. Our system integrates a traditional Deck Decompression Chamber (DDC) securely within a specially designed, buoyant lifeboat hull. This provides divers with a safe and stable decompression environment, even in challenging offshore conditions. Equipped with onboard gas supplies and long-lasting batteries, the SPHL-HRC combination ensures over 72 hours of continuous life support for divers, offering peace of mind during extended operations or emergencies.

While our Hyperbaric Rescue Boats (HRBs) are typically towed by a supporting vessel, they can also be equipped with motors on the transom for self-propulsion. This added feature gives operators flexibility in deployment and operation, making it a versatile choice for various offshore scenarios. The system is designed with a top or side manway, as well as an additional rear mainlock manway, ensuring quick and easy access for divers and personnel during emergencies or standard operations.



DESIGNED AND BUILT FOR YOU

STARTER PACKAGE FOR ALL-IN-ONE SAT DIVING OPERATIONS

We offer an exclusive starter package that includes everything you need to kick off saturation diving operations. Our package is customisable and can include all essential equipment, diver tools, and personal gear based on your specific requirements. Whether you're a new operation or expanding your capabilities, our starter package ensures you have all the necessary equipment to begin your operations smoothly and effectively, removing the hassle of sourcing multiple components from various suppliers.

FLEXIBLE ACCOMMODATION CAPACITY (6-TO-18-MAN OPTIONS)

We provide a range of system configurations to suit various operational needs, with options for systems that can house anywhere from 6 to 18 divers. This flexibility allows you to scale your operations according to the scope and size of your projects. Whether you're handling smaller jobs or large-scale, complex operations, we have a solution tailored to your capacity requirements, ensuring operational efficiency and safety.

VERSATILE LAUNCH OPTIONS: OVERSIDE OR MOONPOOL

Our systems are designed for both outside and moonpool launches, offering flexibility depending on your vessel setup and operational preferences. This adaptability ensures that you can make the most of your vessel's capabilities, improving efficiency and reducing the limitations on operational conditions. Our systems are built with the versatility to fit seamlessly with either method, ensuring smooth and safe launches for all diving operations.

COMFORTABLE LIVING ENVIRONMENT FOR DIVERS

We understand that diver comfort is a key factor in maintaining efficiency and morale during long-term operations. That's why our living quarters are designed with the divers' well-being in mind. Our systems provide a clean, well-ventilated, and spacious environment with attention to ergonomics and comfort. A pleasant and practical living space can enhance productivity, ensuring divers are well-rested and ready to work.

HIGH-QUALITY ENTERTAINMENT SYSTEM FOR DIVERS

During saturation diving operations, divers may spend extended periods in decompression chambers. To keep morale high, our systems are equipped with high-quality entertainment systems, offering divers the ability to relax, stay mentally engaged, and reduce the stress of the long isolation periods. We provide a range of options for media, including TV and music.

REDUNDANCY ON THE LAUNCH AND RECOVERY SYSTEM (LARS)

Safety is always a priority in any diving operation, and our systems incorporate redundancy features within the Launch and Recovery System (LARS). This redundancy ensures continuous operation, even in the event of equipment failure, providing peace of mind and a safeguard against unexpected delays or complications. By building backup systems into critical processes, we help ensure the highest standards of safety and reliability.

SEMI OR FULLY AUTOMATIC CONTROL OPTIONS

We recognise that different clients have varying preferences when it comes to system controls. Whether you prefer simple, semi-automatic controls for basic operations or fully automated, sophisticated systems for more complex needs, we can customise the control systems to meet your requirements. This flexibility ensures that your team has the level of control and automation that best suits your operational style.

EASY INSTALLATION AND MODULAR DESIGN

Our systems are designed with ease of installation in mind, especially when it comes to modular setups. Whether you're installing our systems on a new vessel or integrating them into an existing one, we ensure a streamlined and time-efficient installation process. The modular design of our systems reduces the complexity of installation, minimising downtime and allowing for quicker deployment.



REFURBISHMENT

In addition to providing cutting-edge new systems for saturation diving operations, SMP also offers a refurbishing service. This service allows us to breathe new life into your existing equipment, ensuring that it meets all operational standards and complies with industry regulations. We don't just restore your equipment to its former functionality; we can also modify and upgrade it to meet any specific requirements or operational goals you may have.

Our refurbishing option is well-suited for projects where cost-effectiveness is a key concern. By opting to refurbish rather than purchase new equipment, you can significantly reduce expenses without compromising on safety, performance, or compliance. This solution enables you to extend the lifecycle of your assets, ensuring they remain fully functional and reliable while meeting the latest technological and regulatory standards.

This option can also save on time, reducing the 'time to first dive':

ON-DECK SYSTEM

Refurbished: Estimated time to first dive 14 months
New: Estimated time to first dive 22 months

INBUILT MODULAR SYSTEM

Refurbished: Estimated time to first dive 17 months
New: Estimated time to first dive 25 months



BEFORE

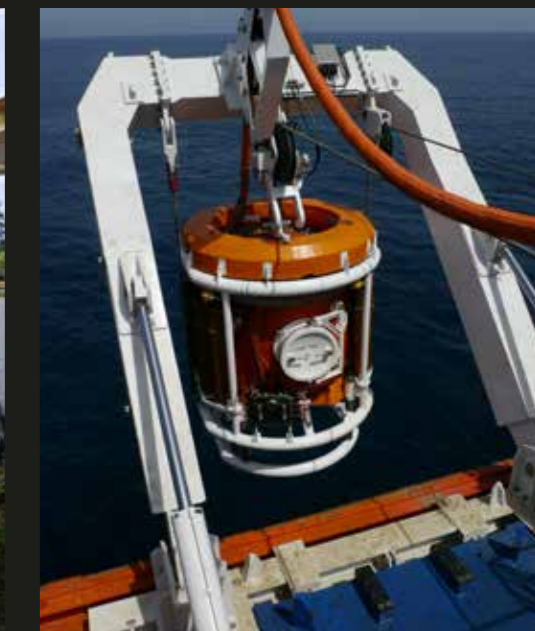

AFTER

BENEFITS OF WORKING WITH SMP

COMPREHENSIVE TRAINING PACKAGE WITH UK-BASED SAT DIVER ACADEMY PARTNERSHIP

One of the biggest advantages of partnering with us is our close relationship with a leading UK-based saturation diver training academy. This collaboration allows us to offer a full-service package that goes beyond just equipment. We can ensure that your divers receive top-tier, certified training directly from a recognised academy, giving you a competitive edge by providing both cutting-edge technology and well-trained operators. This integrated approach helps streamline the transition to using our systems, making sure your team is fully equipped with the knowledge they need.

EXPERIENCED TEAM

Our team brings a wealth of experience and expertise, enabling us to work closely with shipyards during installation. We have a proven track record of interfacing directly with shipbuilders to ensure a cost- and time-efficient installation process. From initial planning to execution, our team provides hands-on support to ensure smooth project completion, keeping timelines and budgets on track.

SOLUTIONS FOR NEW VESSELS OR CONVERSIONS

Whether you're building a new vessel or converting an existing one, our systems are adaptable and designed to fit seamlessly into various configurations. We provide tailored solutions for new builds as well as for retrofitting older vessels. Our engineering team works closely with your project managers to ensure the system is integrated effectively into your vessel's design.

CLOSE COLLABORATION WITH CLASSIFICATION SOCIETIES

Compliance is critical when it comes to saturation diving systems, and we ensure that our equipment meets all necessary standards. We work closely with leading classification societies to ensure that every system is fully compliant with the latest industry standards and regulations. This collaboration ensures a smooth approval process, giving you confidence that your operations will be up to code and safe for all involved.



SMP DESIGN AND DUE TO DELIVER SATURATION DIVING SYSTEM FOR PDA, ENHANCING DIVER TRAINING IN THE INDUSTRY

Closed bell diver training is a prerequisite to all saturation diving operations globally, yet there is a significant shortfall on training options internationally, with more forecast closures on the horizon, the Professional Diving Academy, in collaboration with SMP has been working to prevent a potential incoming manning crisis.

The Professional Diving Academy, like many other industry professionals, have been concerned by the absence of an IMCA approved, UKHSE accredited, open water closed bell training facility in the UK. Our frustration being the limited support for diver training centres and how it impacts the training opportunities and resources available to divers. This frustration has driven us to explore new, more commercially sustainable, closed bell diver training models. Training centres are pivotal in providing divers the building blocks for a long and safe career, fundamental to maintaining safety not only in North Sea, but around the world.

The Professional Diving Academy (PDA) has a global reputation for delivering high quality UKHSE accredited commercial diver training. Having just celebrated its 20th anniversary, its internationally recognised certification has been the default choice for many commercial divers around the world. Until now PDA has not offered a closed bell training course, based around the commercial restraints of operating a training system to the standards required by industry and providing consistent training, with equipment relevant to the industry.

The PDA, in collaboration with Submarine Manufacturing Products Ltd (SMP), is building a purpose-built closed bell training system which will offer a robust closed bell training option (at the PDA diver training facility) on the Firth of Clyde on the Westcoast of Scotland.

The proposed system has been designed to provide a safe, realistic, and compliant training environment which is specially

configured to maximise PDA's new closed bell training syllabus a subtle distinction between it and a commercial saturation diving system.

The PDA will operate the system, maintaining the system, will be in collaboration with SMP and industry. Courses will be carried out with experienced trainers with current, 'real world' experience of Offshore Saturation Diving operations, in both normal and emergency scenarios to ensure the training experience best equips the divers for their entry into commercial diving operations.

The closed bell training centre is intended to be a collaboration between PDA, regulators and the industry during its build and operation. Opportunities for the industry to get involved in the build of the system will be socialised over the coming months, PDA hope that the centre becomes an industry inclusive capability that adds value to all.





SMP have been manufacturing specialised underwater equipment for over 35 years and we pride ourselves on providing the highest quality subsea systems alongside excellent customer service.

We are agents for leading manufactures such as Kirby Morgan Diving Helmets, Broco, Coltri Compressors and Outland Technology and we are also IMCA members.

We have expanded our product range to meet the specific demands of the saturation diving industry. At SMP, we design and manufacture our own equipment, delivering a wide variety of high-quality products to clients around the globe. We also offer products including diving helmets, air compressors, air cylinders, underwater tools, lighting, and advanced camera systems, all designed to support safe and efficient saturation diving operations. Whether it's for deep-sea exploration or complex underwater maintenance, these products are built to meet the rigorous requirements of the industry.



HOT WATER MACHINES



DIVE CONTROL MODULE



HP, LP NITROX AND CNG COMPRESSORS



AIR AND MIXED GAS PANELS



GAS STORAGE

SUPPORTING SYSTEMS

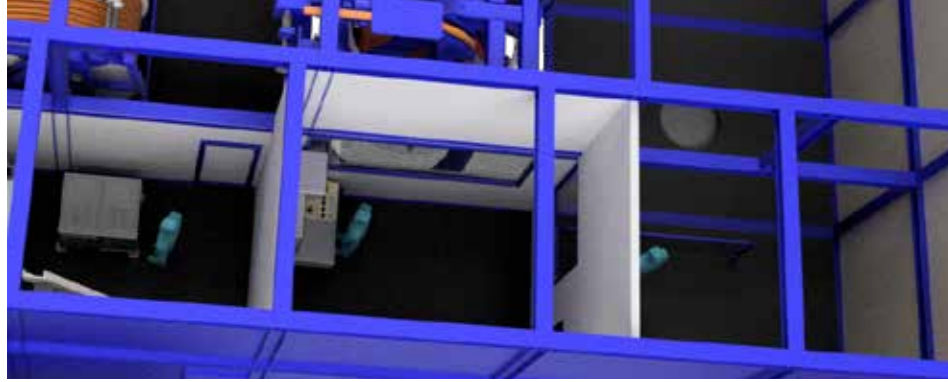

DIVE CONTROL MODULE

The Exo Structure houses a Dive Control Module containing control panels and instruments for the Bell, Dive Machinery, and a separate panel for the PLC-controlled LARS. This self-contained, climate-controlled module ensures operator comfort and protects the equipment from the elements. Each control element is ergonomically designed, with strategically placed windows and CCTV for enhanced navigational support.

The Dive Control panel includes the following features and services within the system:

- Depth monitoring system (DDC1 TUP, Bell Int, Bell Ext & Divers)
- Pressurisation and Exhaust
- Diver Gas Distribution
- Divers gas reclaim control panel
- CO2 and O2 analysis including calibration connectivity
- Oxygen injection
- Temperature and humidity monitoring
- Online Gas Distribution and pressure regulation
- Int/Ext lighting, Emergency scrubber/heater control
- Hot Water Temperature Monitoring
- Helium Un-scrambler Communication Radio
- CCTV Monitoring System with HDD recording
- Uninterruptible Power Supply (UPS)
- DP Audio / Visual monitoring and alarm system
- Diver Monitoring System with HDD storage
- Operator BA

GAS DISTRIBUTION PANEL

The gas supply to the Diving System is controlled by the Gas Distribution Panel, which distributes gas to all users. This panel consists of modular high-pressure sections that deliver gas mixtures to consumer panels, such as Dive Control and SAT Control Panels. Each section includes a pressure gauge and valves for gas distribution control, along with a vent valve for depressurizing the interlink hoses.

HELIOX

Multiple high-pressure Heliox cylinders are stored in the Tank Top machinery area. Operational data and volumetric requirements need to be assessed. SMP should be informed to assist with storage bank calculations based on potential usage.

AIR

Multiple high-pressure air cylinders are stored in the Tank Top machinery area. Operational data and volumetric requirements must be determined. SMP should be notified to assist with storage bank calculations based on anticipated usage.



AIR COMPRESSORS

An LP Compressor supplies 13-bar low-pressure (LP) breathing air, maintaining air quality through a refrigerant dryer and three-stage filtration system. The dryer removes moisture, while the refrigerant system cools the air, causing condensate to drain automatically. The dried air is sent to the LP Air Receiver, equipped with isolation valves, a drain valve, a pressure gauge, and a safety relief valve. The system meets BS EN 12021-2014 standards with coalescing and particulate filters, and isolation valves for easy maintenance.

A 300-bar high-pressure (HP) compressor charges the HP Air Storage. Air is filtered, compressed, and meets BS EN 12021-2014 standards. Features include auto stop, condensate drain, low oil shut-off, and charging connectors. Filter saturation is indicated visually, and the air is distributed to charging outlets and an external interface.

HOT WATER MACHINE

The Hot Water Unit delivers a mix of hot and cold water through the umbilicals to keep divers warm. The water temperature is raised to offset heat loss in the system, ensuring it's warm enough without being uncomfortable or dangerous. Pressure is maintained to provide adequate flow.

The system has two circuits for hot and cold water, both sourced from seawater, which passes through filters and regulators before reaching a 3-way mixing valve. Heated seawater is pumped to ensure proper flow and pressure, with temperature adjustments made locally or remotely from Dive Control.

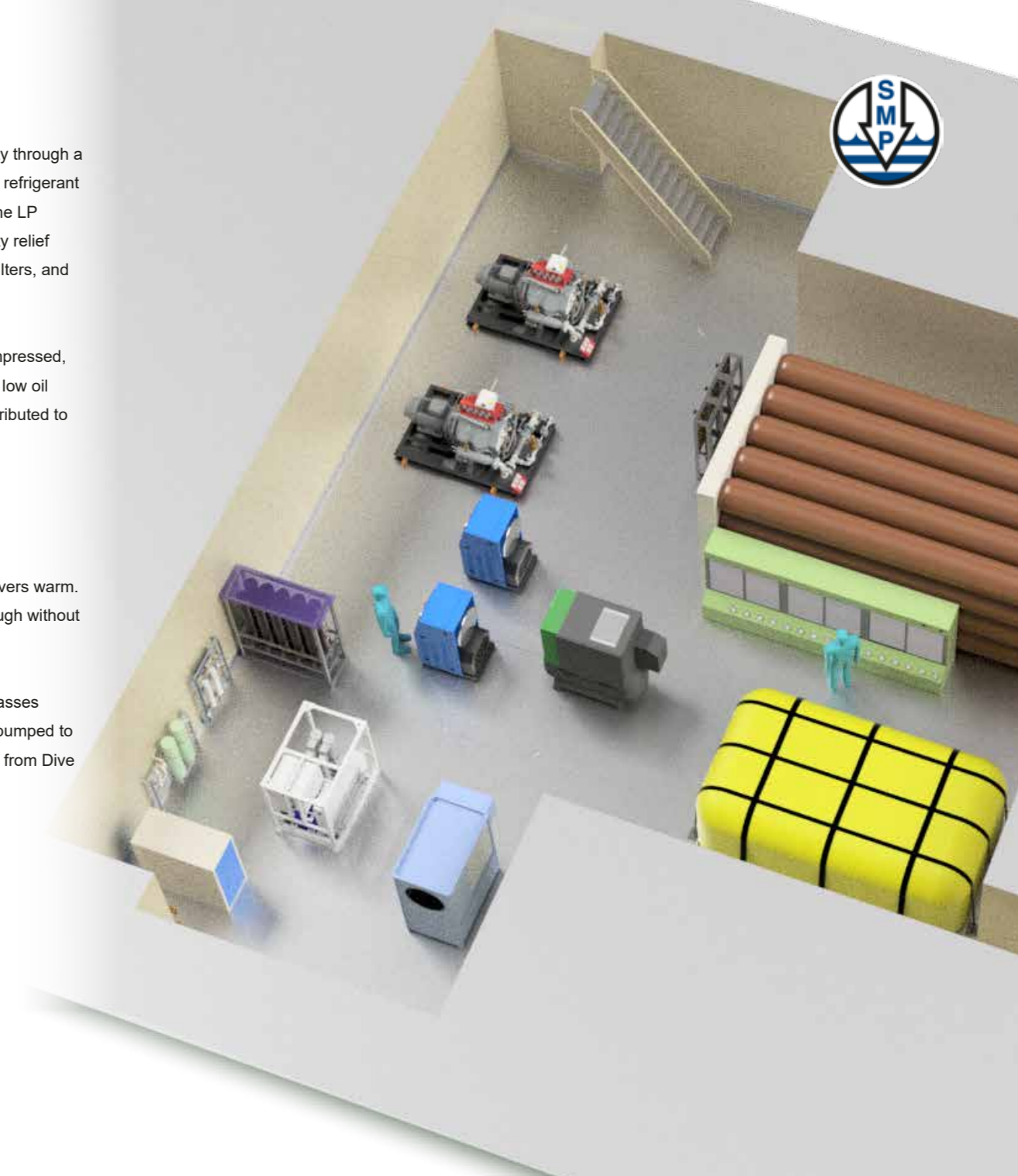



SMP is proud to be a trusted supplier of high-quality equipment to the saturation diving industry. With a comprehensive range of products, we meet the specialised needs of commercial divers working in extreme underwater environments. Our commitment to excellence is reflected in the diverse selection of gear we offer, including diving helmets, bailout systems, hot water suits, video and communications devices, and more.

SMP work with Kirby Morgan to offer diving helmets that are designed with advanced technology to ensure optimal visibility, comfort, and reliability for saturation divers. SMP are an authorised distributor, service centre and training centre for Kirby Morgan, with a team of trained and qualified experts.

Our bailout systems and hot water suits are engineered to withstand the harsh demands of saturation diving. Built from durable, high-performance materials, they offer the support, insulation, and flexibility needed to perform effectively in challenging environments. SMP understands the unique needs of saturation diving, and our equipment is tailored to exceed industry standards.

In addition to personal gear, SMP provides cutting-edge video and communications devices, critical for maintaining clear communication and real-time monitoring during deep-sea operations. These devices are equipped with the latest technology, ensuring smooth coordination among dive teams and accurate recording of mission data for analysis and documentation.

With a long history of supplying the saturation diving industry with high-quality equipment, SMP has established itself as a reliable partner. Our commitment to innovation, safety, and customer satisfaction has earned us a reputation as a preferred supplier for diving contractors worldwide.

DIVER'S EQUIPMENT



DIVING EQUIPMENT

SMP partners with leading brands like Kirby Morgan, C-Tecnic, Outland Technology, and Amron International to offer a comprehensive range of high-quality diving equipment. We supply industry-standard gear such as Kirby Morgan diving helmets, durable harnesses, video monitoring systems from C-Tecnic, and reliable communication systems for safe diving operations.

Additionally, through Outland Technology and Amron International, we provide advanced diving lights, tools, and accessories to enhance underwater performance. By working closely with these top brands, SMP ensures our clients have access to the best equipment for safe and successful diving operations.



DIVING HELMETS AND MASKS



DIVING SUITS, VESTS AND HARNESSES



UNDERWATER VIDEO SYSTEMS



DIVERS COMMS



UNDERWATER TOOLS

SUPPLYING DIVERS ACROSS THE WORLD SINCE 1985



For over 35 years, SMP has provided exceptional customer service and high-quality solutions to the saturation diving industry. Our success is driven by the expertise and dedication of our team, which includes industry specialists, former commercial divers, experienced design engineers, and a skilled workshop of certified engineers, electricians, and fitters. Without their contributions, we wouldn't be where we are today.

To meet the growing demands of the saturation diving industry, SMP has evolved to offer comprehensive system design and manufacturing solutions. Whether the project is highly complex or requires a long-term approach, we collaborate closely with our clients to ensure their objectives are met. Many of our systems are custom-built, tailored to the unique requirements of each customer, ensuring a perfect fit for their operational needs.

We understand that downtime in the saturation diving industry can have serious consequences, impacting safety and operational continuity. SMP is committed to minimizing those risks by offering round-the-clock support from our team of experts. Through continuous communication and personalized assistance, we provide solutions that keep your operations running smoothly. Our extensive experience and resources allow us to respond quickly to emerging challenges, delivering bespoke systems that meet the critical needs of offshore diving contractors and commercial diving companies worldwide.

SMP is a globally recognized leader, trusted by clients around the world, including major players in the offshore sector. We pride ourselves on offering a complete service package, from design and manufacturing to ongoing support, setting us apart in the marketplace as a reliable and innovative partner for saturation diving operations.

SUPPORT



REFURBISHMENT AND MAINTENANCE

At SMP, we take great pride in our team of highly skilled and experienced engineers, who are leaders in delivering top-quality refurbishment and maintenance solutions for the saturation diving industry. With extensive expertise, our engineers are fully equipped to ensure that commercial diving systems not only operate efficiently but consistently perform at peak levels, ensuring safety and reliability in demanding underwater environments.

We provide a comprehensive contractor-maintained solution, ensuring that your diving equipment is always operational. Our engineers can perform on-site maintenance, so your gear is always ready for use at its base. You focus on the dive; we ensure the equipment is dive-ready.

Recognizing the challenges of acquiring new equipment in the commercial diving sector, we offer refurbishment services as a cost-effective alternative. SMP has successfully undertaken refurbishment projects for a variety of clients, including extensive work on Launch and Recovery Systems (LARS), Deck Decompression Chambers (DDCs), and portable decompression chambers.

With a deep well of experience, our engineers can service a wide range of diving equipment, from complex machinery to advanced electronics. Whether you're dealing with aging systems or intricate equipment, our team has the technical expertise to restore and optimise your gear, ensuring it meets or exceeds industry standards for safety and performance.



SMP Workshop

SMP have two workshops based in the UK allowing for large scale systems to be brought to site and refurbished from our team of qualified engineers.

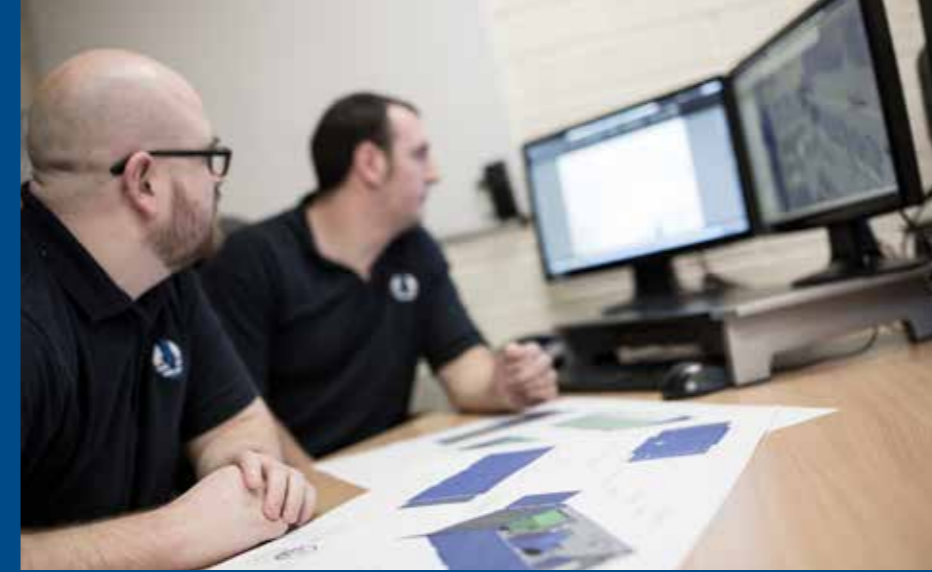

TRAINING

At SMP, we prioritise not only developing state-of-the-art saturation diving equipment but also empowering commercial diving operators and offshore personnel to maximize its performance. Understanding that proper operation is crucial for both safety and efficiency, our team of experts is dedicated to providing comprehensive training tailored specifically for the saturation diving industry.

Our training programs are designed to meet the unique needs of saturation diving professionals. Whether conducted at your location or at our facilities, our sessions ensure that your team gains the skills needed to operate and maintain

diving systems with confidence. Led by seasoned trainers, including former divers and industry professionals, our programs provide practical, real-world insights into the challenges and demands of saturation diving.

We also offer "train the trainer" programs, equipping your internal teams with the knowledge and resources to educate future personnel on the operation and maintenance of critical equipment. Whether you are implementing new systems or enhancing the skills of your existing team, our training sessions cover every aspect of equipment usage, from setup and operation to troubleshooting and maintenance.

SMP Training Facility

Our training facility hosts various training courses for diving equipment, diving panels, system maintenance and operation courses.

SMP is an authorised training centre for Kirby Morgan products, offering diving helmet repair and maintenance courses.

WORLDWIDE SUPPLIER

“
A GLOBALLY RECOGNISED
NAME IN THE SUBSEA
INDUSTRY

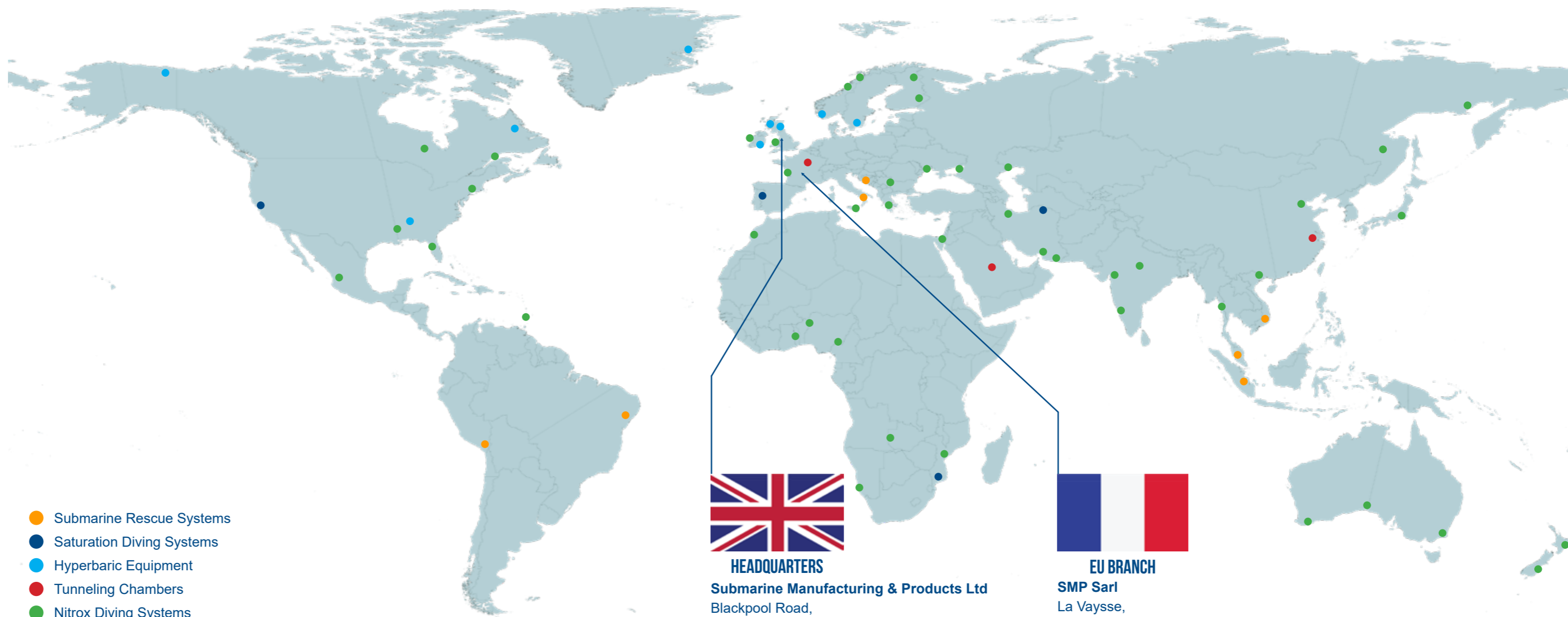

- Submarine Rescue Systems
- Saturation Diving Systems
- Hyperbaric Equipment
- Tunneling Chambers
- Nitrox Diving Systems



HEADQUARTERS

Submarine Manufacturing & Products Ltd
Blackpool Road,
Preston,
Lancashire, United Kingdom
PR4 3RE

Tel: +44 (0)1172 687775
Email: sales@smp-ltd.co.uk



EU BRANCH

SMP Sarl
La Vaysse,
24540,
Vergt de Biron
France

Tel: +33 5 53 23 85 90
Email: sales@smp-sarl.eu



 www.smp-ltd.com

 sales@smp-ltd.co.uk

 +44 (0)1772 687775

